

§1 Introduction to AC-DC Transfer Standards

1.1 Historical background

The ac-dc transfer standard is one of the basic electrical standards, by which the ac voltage and ac current are deduced from their dc counterparts in the frequency range between 10 Hz and 1 MHz [1,2]. The dc voltage standards are established using a Josephson voltage standard with uncertainty better than 10^{-7} [3-5]. The ac voltage standard in the frequency range 10 Hz to 1 MHz are derived from the dc voltage standard by the following two methods, as illustrated in **figure 1.1**.

- (a) Direct synthesizing of ac (sine) waveform by the use of high-precision D/A converter.
- (b) Comparison of electric power between ac- and dc-voltage by converting the power to force or heat.

In the latter case, converters may be recognized as a reference standard, and the system of the standard based on this principle is called the “ac-dc transfer standard”. The most accurate ac-dc transfer standards are realized by the use of “thermal converters”. The thermal converter is capable of comparing the joule heating between ac and dc modes at 0.1 ppm level, and are widely employed as the primary standard in the most of the national standard laboratories [6-8].

As shown in **figure 1.2**, the thermal converters were developed in the 1950s and are still widely used in the field of ac-dc transfer standards [9-11]. Four types of thermal converters have been developed as ac-dc transfer standards, that is, Single-Junction thermal converters (SJTCs), Multijunction

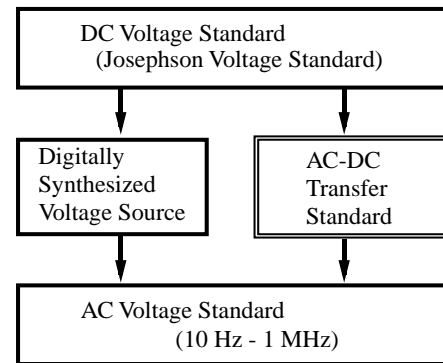

Figure 1.1 Two methods to derive ac voltage standard in the frequency range 10 Hz to 1 MHz from the dc voltage standard. Method 1: Direct synthesizing of sine-wave by high-precision D/A converter. Method 2: Comparison of ac and dc quantity by the use of ac-dc transfer standards.

thermal converters (MJTC), thin-film (planar) MJTC, and semiconductor rms sensors. The detailed descriptions on the four types of the thermal converters are given in section 1.2.2.

On the other hand, the accuracy of the waveform-synthesizing methods has been drastically increased with the improvement of the high-speed analog switches. The most accurate waveform-synthesizing source presently available can produce sinusoidal waveform with a precision of 1 ppm level up to 100 Hz [21]. Recently, D/A converters based on the Josephson devices are under development [22-24]. The pre-

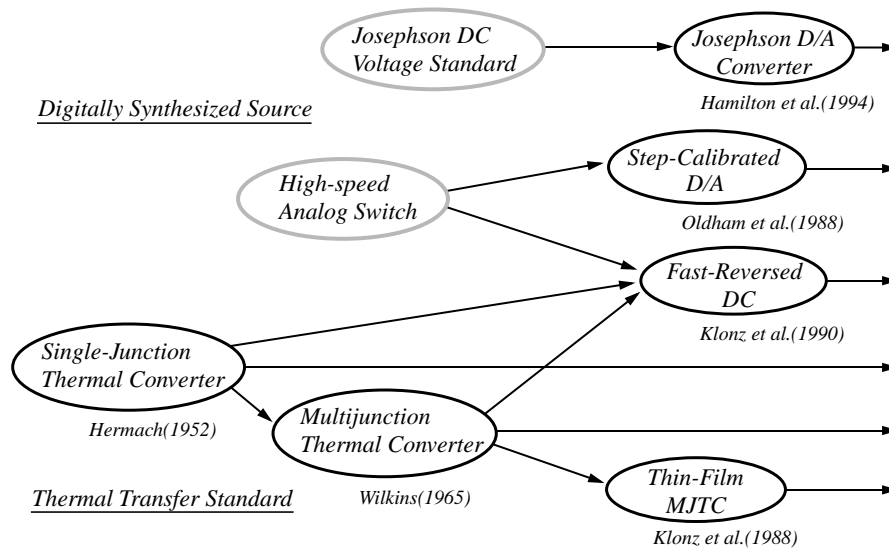

Figure 1.2 Schematic diagram for illustrating the historical relationship between various methods developed for the realization of ac voltage/current standards.

cision which equals to that of dc Josephson voltage standard could be realized with this method. These waveform-synthesizing methods are further described in section 1.2.4.

Another important progress in the area of ac-dc transfer standards is the development of the “Fast-reversed dc” (FRDC) method [25-29], which is also based on the waveform-synthesizing technique. The FRDC method has made it possible to measure the thermoelectric effects of a thermal converter which is the main cause of the ac-dc difference. The FRDC method may be regarded as a combined technology between the thermal method and the waveform-synthesizing methods. The principle of the FRDC methods is described in section 1.2.5.

1.2 Methods of ac-dc transfer standards

1.2.1 Definition of ac-dc difference

The ac voltage is defined by the root-mean square (rms) value of the sinusoidal waveform;

$$V_{AC}(rms) \equiv \sqrt{\frac{1}{T} \int_0^T \{V(t)\}^2 dt}. \quad (1.1)$$

According to the definition, it is possible to compare the ac voltage with the dc by way of the electrical power. In the thermal method, dc and ac voltage are alternately applied to the heater of a thermal converter. Then the amounts of joule heating are compared by measuring the temperature of the heater by a thermocouple.

When dc and ac voltage of equal power are applied to the input of an ideal thermal converter, output EMFs should be the same for both of the inputs. However, in the case of an actual thermal converter, the output EMFs are influenced by the effect of non-joule heating and frequency characteristic of heater circuit. The “ac-dc transfer difference” is the principal quantity in the ac-dc transfer standard, and is defined by the following equation [32].

$$\delta_{AC-DC} \equiv \left. \frac{V_{AC} - V_{DC}}{V_{DC}} \right|_{E_{AC}=E_{DC}} \quad (1.2)$$

Here the quantities E_{DC} and E_{AC} represent the output EMFs of the thermocouple when the dc voltage V_{DC} and the ac voltage V_{AC} are applied to a thermal converter. In the case of an ideal thermal converter ($\delta_{AC-DC}=0$), we get the condition $E_{AC}=E_{DC}$ for the equal input voltage ($V_{DC}=V_{AC}$). While in the case of an actual thermal converter, the V_{AC} is adjusted by an amount $\delta_{AC-DC} \times V_{DC}$ with respect to V_{DC} in order to get the condition $E_{AC}=E_{DC}$. If larger ac-input voltage is required to produce the same EMF output for the dc voltage, the thermal converter has a positive ac-dc difference. (The ac-dc transfer difference δ_{AC-DC} is often abbreviated as “ac-dc difference”).

It is often more convenient to modify the definition of

the ac-dc transfer difference (1.2) such that the condition ($E_{AC}=E_{DC}$) is replaced by the input condition ($V_{DC}=V_{AC}$). Since the V_{AC} is very close to V_{DC} , the input-output characteristic of a thermal converter $E_{DC}(V_{DC})$, $E_{AC}(V_{AC})$ can be approximated by a linear function in the vicinity of the input voltage V_0 ;

$$\begin{aligned} E_{AC}(V_{AC}) &\cong E_{AC}(V_0) + \frac{dE}{dV}(V_{AC} - V_0) \\ E_{DC}(V_{DC}) &\cong E_{DC}(V_0) + \frac{dE}{dV}(V_{DC} - V_0) \end{aligned} \quad (1.3)$$

Using (1.3), the following equality is deduced:

$$\begin{aligned} \frac{E_{AC}(V_{AC}) - E_{DC}(V_{DC})}{n \cdot E_{DC}(V_{DC})} &= \frac{E_{AC}(V_0) - E_{DC}(V_0)}{n \cdot E_{DC}(V_0)} + \frac{V_{AC} - V_{DC}}{V_{DC}} \\ \text{here, } n &\equiv \left(\frac{dE}{E} \right) / \left(\frac{dV}{V} \right). \end{aligned} \quad (1.4)$$

The “normalized index” n is of the order of 2, which represents the square characteristic of input-output response function of thermal converters.

From (1.2) and (1.4), we get the equation to calculate the ac-dc transfer difference from the output quantities:

$$\delta_{AC-DC} \cong - \left. \frac{E_{AC} - E_{DC}}{n \cdot E_{DC}} \right|_{V_{AC}=V_{DC}}. \quad (1.5)$$

In order to measure the ac-dc difference of a thermal converter with an accuracy of 1 ppm, the ac input voltage with a precision of better than 1 ppm is required. In a reversed way, if the ac-dc difference of a thermal converter is evaluated with a precision of 1 ppm, it is possible to measure the ac voltage with 1-ppm accuracy. Due to these circumstances, the ac-dc difference is recognized as the most important quantity in the ac voltage/current standard, and the term “ac-dc transfer standard” are frequently used as an equivalent term to the “ac voltage/current standard”.

1.2.2 Thermal converter

Four types of thermal converters have been developed for the realization of ac-dc transfer standard at 1-ppm level. They are Single-Junction thermal converters (SJTCs), Multijunction thermal converters (MJTC), planar-type MJTC, and semiconductor rms sensors.

(1) Single-Junction Thermal Converter

The Single-Junction Thermal Converters (SJTC) are developed at 1950s [9-11]. The ac-dc transfer standard with accuracy of 1 ppm-level has been established at NIST[6] in the 1960s using the SJTC. The construction of a typical SJTC element is shown in **figure 1.3**. A thin filament-heater and a thermocouple are inserted in a vacuum-shielded glass bulb.

The thermocouple thermally contacts with the heater at the midpoint of the heater using a bead made of electrically insulating material such as glass or ceramics.

Since the EMF output of the SJTC element is of the order of a few mV, a precise dc-voltage measurement of nV-level is required in order to obtain the resolution better than 1 ppm. Due to its simple structure, the SJTC elements shows a flat frequency response up to GHz region. The long term-drift in the ac-dc transfer difference is negligibly small. The SJTCs are still widely used in the ac-dc transfer standard and in the ac power standard. The primary ac-dc standards of Japan are also maintained using the SJTC elements at ETL and the Japan Electric Meters Inspection Corporation (JEMIC) [30-31].

(2) Multijunction Thermal Converter

The Multijunction Thermal Converters (MJTC) are developed in 1970s to 1980s [12-15]. The MJTCs are designed to reduce the thermoelectric effect, which is the main cause of ac-dc difference around 1 kHz. The construction of a Wilkins-type MJTC [13] developed at Physikalisch Technische Bundesanstalt (PTB: Germany) is shown in **figure 1.4**. The MJTC employs many numbers of thermocouples along the heater for the purpose of producing uniform temperature distribution in the heater. The twisted bifiler heater

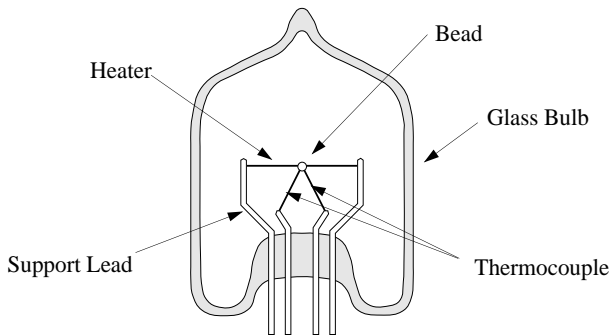

Figure 1.3 Construction of a typical SJTC element. A thin filament-heater and a thermocouple are inserted in a vacuum-shielded glass bulb. A thermocouple is attached to the heater at the midpoint of the heater using a bead made of glass or ceramics.

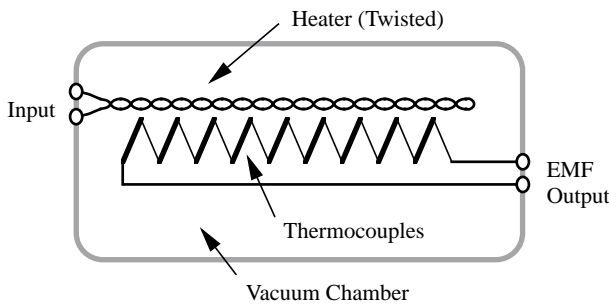

Figure 1.4 Construction of a Wilkins-type MJTC. Use of many numbers of thermocouples and the twisted bifiler heater is for compensating the thermoelectric effects.

is used for the purpose of compensating the first-order thermoelectric effects. In the case of PTB-design MJTC, the series-connected Cu-CuNi thermocouples are produced by sputtering copper to half-circumference of the rectangular coil made of thin CuNi44 wire.

Owing to the uniform temperature distribution, the thermoelectric effects along the heater are reduced, and the ac-dc difference better than 0.1 ppm is obtained. The output EMF is also increased to 100 mV level due to the increased number of thermocouples. The disadvantages of the MJTC originate from its complex structure. The MJTCs have larger frequency dependence, weakness to electrostatic breakdown, and difficulty in mass-production. The MJTCs are widely used in the national standard laboratories as the most reliable basis for the ac-dc transfer standard.

(3) Thin-Film (Planar) MJTC

Recently, another type of MJTC has been developed using the thin-film technology [16-19]. The construction of a thin-film MJTC developed at PTB is illustrated in **figure 1.5**. The heater and the hot-junctions of the thermocouples are formed on the SiO₂/Si₃N₄ sandwich membrane, and the cold-junctions of the thermocouples are formed on the Si-substrate. This type of MJTC has been realized by the advance in the technology of forming the thin-films using the isotropic-etching. The advantage of the thin-film MJTC is that it is suitable to mass-production. The development of thin-film MJTCs are one of the main subject in the research of ac-dc transfer standard, and are expected to replace the conventional thermal converters in near future.

(4) Semiconductor rms Sensor

A semiconductor rms sensor [20] has been developed by

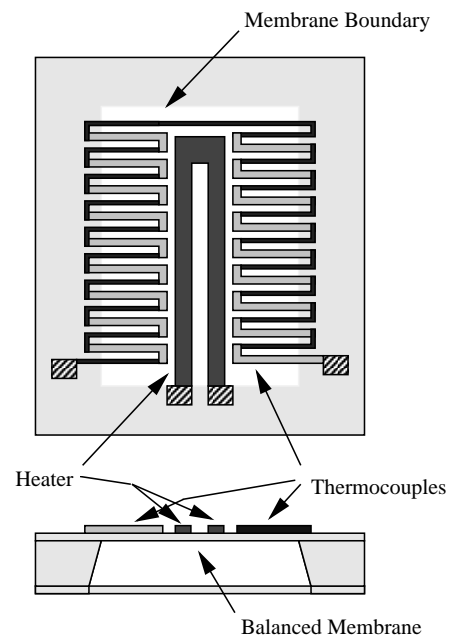

Figure 1.5 Construction of a thin-film MJTC developed at PTB. The heater and the hot-junctions of the thermocouples are formed on SiO₂/Si₃N₄ sandwich membrane made with an isotropic etching.

Fluke. Co. This rms sensor uses a temperature dependence of the base-emitter junction voltage of a transistor instead of traditional thermocouple for detecting the temperature of the heater. A commercial ac-dc transfer standard (Fluke 792A) which use the rms sensor shows a potential accuracy of better than 1 ppm. Calibration of this instrument with uncertainty better than 5 ppm is requested for national standard laboratories including ETL and JEMIC.

1. 2. 3 Origin of ac-dc difference

There are three main causes of the ac-dc transfer difference in the case of an SJTC:

(1) Thermoelectric effect (dc offset): When the dc current is passed through the heater of an SJTC, non-joule heating/cooling takes place along the heater due to thermoelectric effects such as Thomson or Peltier effect. In the case of SJTC with standard construction, an ac-dc difference of a few ppm is observed due to the thermoelectric effects. In the case of MJTC of PTB, the thermoelectric effect is suppressed due to the uniform temperature distribution on the heater, and contribution from the thermoelectric effect is estimated to be smaller than 0.1 ppm.

(2) High-frequency characteristic: In the frequency range above 10 kHz, the skin-effect of the conductor and the stray inductance and capacitance in the input circuit become significant. When a standard-design SJTC-element is combined with a current-limiting metal-film resistor of 1k Ω , the effect to the ac-dc difference is of the order of 0.1 ppm / 1 ppm / 100 ppm at the frequency of 10 kHz / 100 kHz / 1 MHz. The MJTCs generally shows larger high-frequency characteristic due to the dielectric loss in the twisted bifilar heater.

(3) Low-frequency characteristics: The thermal time constant of a standard-design SJTC-element is about 1 s. At frequency below 100 Hz, double-frequency thermal ripple is created due to insufficient thermal inertia. In the case of SJTC, the effect to the ac-dc difference is of the order of 0.1 ppm / 10 ppm at the frequency of 100 Hz / 10 Hz. The MJTCs generally shows smaller low-frequency characteristic due to improved linearity in the input-output characteristic.

The typical frequency characteristics of an SJTC and an MJTC in the full frequency range are illustrated in **figure 1.6**. The thermoelectric effects which occur at the dc-mode give the frequency-independent offset in the ac-dc difference. Since both the low-frequency characteristic and the high-frequency characteristic reduce below 1 ppm in the frequency range between 100 Hz and 10 kHz, the ac-dc difference is dominated by the thermoelectric effect around 1 kHz.

1. 2. 4 Waveform synthesizer

A sinusoidal ac voltage waveform may be synthesized using a high-precision D/A converter with an accurate dc reference voltage. Due to the improvement in the speed and accuracy of D/A converters, the uncertainty in the produc-

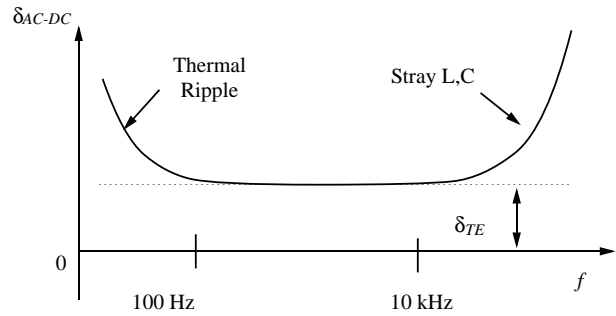

Figure 1.6 The typical frequency characteristics of a thermal converter. Three main causes of the ac-dc transfer difference are; (a) thermoelectric Effect (dc offset) due to the Thomson or Peltier effect, (b) high-frequency characteristics of the input circuit, and (c) low-frequency characteristics due to thermal ripple.

tion of the ac rms voltage is approaching to that of the thermal transfer standards. One example of such precise ac-voltage source is the “step-calibrated” quasi-sine waveform source [21] developed by N. Oldham et. al. of National Institute of Standard and Technology (NIST: USA). The source can produce a high-stability glitch-free 128-step quasi-sine waveform. Calibrating all the 128 steps by high-precision dc reference, quasi-sine waveform can be produced with precision of 1 ppm level in rms value. This method has advantage in the lower frequency (<50 Hz) where the thermal methods tend to lose their accuracy. At the same time, owing to the effect of switching-transient, the accuracy of the synthesized waveform deteriorates with increasing frequency above 50 Hz.

Recently, a more advanced method has been developed by C. Hamilton et. al. of NIST using ac Josephson effect[24]. The absolute voltage is obtained by the relation in the ac Josephson effect as

$$V = nf / K_J . \quad (1.6)$$

Thus the rms ac voltage with fundamental accuracy may be obtained by changing either the step-number n or the microwave frequency f . The schematic circuit diagram of the method is described in **figure 1.7**. In this method, non-hysteretic Josephson Junction Arrays (JJA) are connected in a binary sequence ($2^N = 1, 2, 4, 8, \dots$).

Setting the bias current independently for each set of junctions, and using the first step ($n = 1$), any voltage up to

$$V = \pm 2^N f / K_J , \quad (1.7)$$

may be obtained with N -bit resolution. Using 8192 shunted tunnel junctions, Josephson D/A converter which generates programmable voltage from -1.2V to +1.2 V with 150 μ V steps has been realized[24].

1. 2. 5 Fast-reversed dc

As discussed in section 1.2.3, the accuracy of the ac-dc

difference is limited by the uncertainty in the evaluation of thermoelectric effects which develop along the heater of the thermal converters. The evaluation has been performed theoretically using a mathematical modeling of the thermal converters, considering the properties of the material of the heater and the support lead. However, it is not easy to confirm the accuracy of the theoretical evaluation at 0.1 ppm level.

Recently, an experimental method has been developed at PTB for the evaluation of thermoelectric effects [25]. In this method, rectangular-waveform are synthesized by switching between a positive dc source (DC+) and a negative dc source (DC-) as illustrated in **figure 1.8**. The switching is performed using high-speed analog switches. If the switching is performed in a perfect way, a high-precision rectangular ac waveform is obtained whose rms power is equal to the mean of the two dc sources. The rectangular waveform synthesized in this way is called the Fast-Reversed DC (FRDC) waveform, and the circuit for producing the FRDC waveform is called FRDC source.

Following the definition of the ac-dc difference of a thermal converter given by (1.5), a “FRDC-DC difference” $\delta_{FRDC-DC}$ is defined using the following definition.

$$\begin{aligned} \delta_{FRDC-DC} &\equiv \frac{V_{FRDC} - V_{DC}}{V_{DC}} \Big|_{E_{FRDC} = E_{DC}} \\ &\equiv -\frac{E_{FRDC} - E_{DC}}{nE_{DC}} \end{aligned} \quad (1.8)$$

Here, E_{FRDC} represents the EMF for the FRDC waveform, and E_{DC} represents the mean EMF for the DC+ and DC- waveform.

The thermoelectric effects in thermal converters are evaluated by the measurement of the FRDC-DC difference $\delta_{FRDC-DC}$. The principle of the method is illustrated in **figure 1.9**. For the simplicity, only the Thomson effects along the heater is shown in the figure. When dc current passes

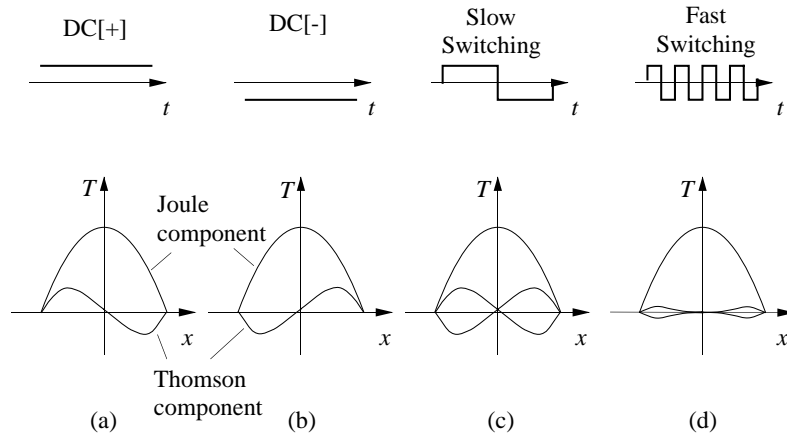

Figure 1.9 Thermoelectric effects in thermal converters with the FRDC waveform. If the reversal of the current is slow enough, the temperature distribution along the heater is similar to that for the steady-state dc. While in the case of fast reversal, the thermoelectric effects do not have time to develop during one period of reversal.

through a thermal converter, the temperature distribution is modified due to the Thomson effect as shown in figure 1.9(a). When the current is reversed, the polarity of the Thomson effect is also reversed, resulting in the different temperature distribution along heater as shown in figure 1.9(b). The

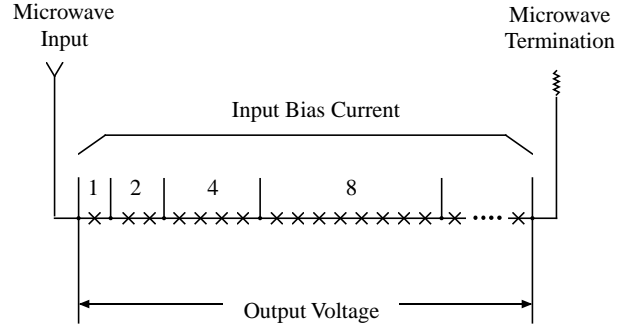

Figure 1.7 The schematic circuit diagram of the Josephson D/A converter. Non-hysteretic Josephson Junction Arrays (JJA) are connected in a binary sequence (1, 2, 4, ...). The output voltage is controlled by setting the bias current independently for each set of junctions.

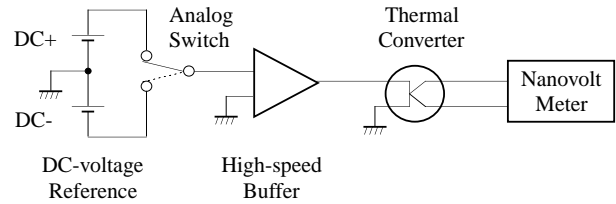

Figure 1.8 Principle of the Fast-Reversed dc source (FRDC) method. The rectangular-waveform are synthesized by switching the output between a positive dc source (DC+) and a negative dc source (DC-) using high-speed analog switches.

characteristic time constants of the change in the temperature distribution due to the Thomson and Peltier effects are determined by the structure and material of the heater, and we hereafter call it “thermoelectric time constants”.

In the case of FRDC mode, if the reversal of the current is slow enough compared with the thermoelectric time constants, the same temperature distribution along the heater is obtained as that for the steady-state dc. Hence the average output EMF of thermal converter in the slow-reversing mode equals to the mean output EMF for DC+ and DC- modes, and the FRDC-DC difference becomes zero. On the other hand, if the reversal of the current is fast enough, thermoelectric effects do not have enough time to develop during one current direction, and the influence of thermoelectric effects is reduced to zero. In this case, the FRDC-DC difference equals to the thermoelectric effect which occurs in the dc modes. Thus, the thermoelectric effects can be determined experimentally by measuring FRDC-DC difference of a thermal converter at some sufficiently high switching frequency with respect to the thermoelectric time constants.

In the case of low-frequency sine wave, the effect of time-constants of thermoelectric effect is dominated by double-frequency thermal ripple due to joule heating. While in the case of FRDC method, the rectangular waveform produces steady-state dc power. No thermal ripple is created at frequencies as low as a few Hz. This property of the FRDC waveform makes it possible to detect the thermoelectric time constant. The method for the evaluation of the thermoelectric time constants will be described in detail in section 6.2.

1. 3 Purpose of the research

In accordance with the recent progress in precision electronic instruments, the accuracy of industrial ac-dc standards has also been improved. The recent models for the industrial standards requires the calibration with an accuracy better than 10 ppm. However, in most of the countries, the accuracy of the primary ac-dc transfer standard stayed a few-ppm level. In Japan, the standard has been established at ETL in 1960s with an accuracy of 5 ppm. For more than two decades, the standard has been maintained with the same precision. As a result, the accuracy of the industrial ac-dc standard exceeded the accuracy of the primary standards maintained at ETL.

In order to meet the demands from the industry and to improve the accuracy of the primary standard, the research on the ac-dc transfer standard was initiated at ETL in collaboration with JEMIC and PTB. The specific goal of the research was as follows;

- (a) Development of new thermal converters for reference standards.
- (b) Development of a new ac-dc difference comparator with improved accuracy.

The research has been carried out during the years 1991 and 1992. A group of SJTCs developed as working primary standards were calibrated by MJTCs from PTB. The achieve-

ments of the research on these subjects are described in chapters 2-3.

On the other hand, a discrepancy as large as 2 ppm in the primary ac-dc transfer standards among different countries have been reported [26]. The discrepancy is supposed to be related to the difference in the structure of the thermal converter, such as SJTC and MJTC, used as a primary standard. Due to the recent improvement of the precision of the ac-dc transfer standards, the discrepancy has become to be non-negligible level. In order to realize ac-dc transfer standards which are globally consistent at 1 ppm level, the settlement of the discrepancy has become an important issue.

In order to contribute to this problem, a research on the FRDC method has been carried out at ETL during the years from 1992 to 1996. The main purposes of the research were as follows;

- (a) Establishment of an independent basis as the primary standard of ETL.
- (b) Investigation for sources of the discrepancy among the national standard laboratories.

Though the original design of FRDC source by M. Klonz et. al. clearly demonstrated the effectiveness of the FRDC method to evaluate the thermoelectric property of thermal converters, the technical difficulties to obtain the equality of the rms power has also been shown clearly. The difficulty is caused by imperfect switching of the analog switches and the effect of higher frequency component of the rectangular waveform.

A new modified waveform of the fast-reversed dc has been proposed by the authors in order to overcome these difficulties [27,28]. New FRDC sources which are based on the modified waveform have been developed at ETL in collaboration with JEMIC, PTB, and the National Measurement Laboratory of Australia (CSIRO/NML). The FRDC sources have successfully been used for the evaluation of the thermoelectric effects in thermal converters at sub-ppm level. The modified waveform has also been used for a FRDC experiment at NIST using the Josephson-based DA converter [24]. The development of the FRDC source is the main subject of the research, and will be described in detail in chapters 4 to 8.